



**Installation Manual
For
Dimension4™ Sonata
Home Cinema Acoustical Tuning System**



Distributed by Media Specialty Resources, Inc.
61 Galli Drive, Suite A, Novato CA94949, USA
Toll Free: 1-800-497-2087
Tel: 1-415-883-8053
Fax: 1-415-883-8147
Email: info@msr-inc.com
www.msr-inc.com

Introduction

Every home cinema is affected by room acoustics. Allow the articulation, tonal balance and clarity of the speakers to be heard. Don't chance missing important elements within the soundtrack. The Dimension4 Sonata acoustical tuning system is a high value, easy-to-install solution for home cinemas and listening rooms. Based on scientifically designed building blocks including absorbers, diffusers, bass filters, and ceiling panels, Sonata provides optimum absorption and diffusion in a full-frequency component solution.

Sonata is available in two configurations, "standard", or "Plus". The standard system is made of 2" (5cm) thick modules. The "Plus" system is made of 4" (10cm) and 6" (15cm) modules, and is effective over a broader range of frequencies.

Sonata modules and panels can be installed in minutes by observing the following simple instructions.

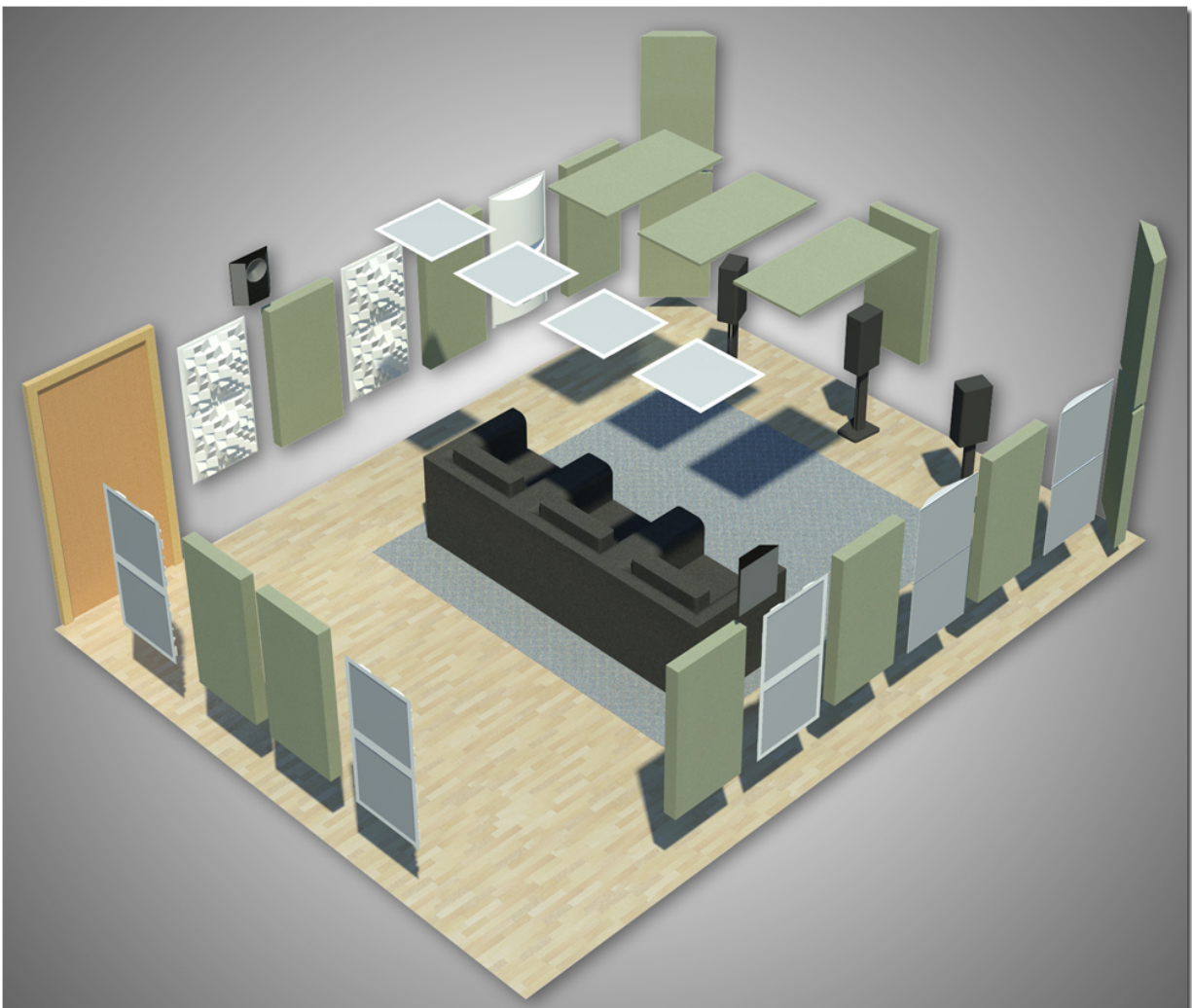

Building Blocks



Sonata Absorber:

Construction: A 24" x 48" (60cm x 120cm) panel consisting of a mineral wool core clad in a fiberglass lining and wrapped in fabric, 2" (5cm) for standard systems. 4" (10cm) thick for "Plus" system.

Benefits: Provides absorption down to 250 Hz



DC2: for standard system

Construction: A 24" x 24" x 2" (60cm x 60cm x 5cm) 2D diffuser module made of ABS

Benefits: Provides horizontal diffusion down to 800 Hz by means of cylindrical re-radiation



DC4: for "Plus" system

Construction: A 24" x 24" x 4" (60cm x 60cm x 10cm) 2D diffuser module made of ABS

Benefits: Provides horizontal diffusion down to 600 Hz by means of cylindrical re-radiation



DR2: for standard system

Construction: A 24" x 24" x 2" (60cm x 60cm x 5cm) 3D diffuser module made of ABS

Benefits: Provides hemispherical diffusion down to 800 Hz by means of triangular scattering cells



DR6: for "Plus" system

Construction: A 24" x 24" x 6" (60cm x 60cm x 15cm) 3D diffuser module made of ABS

Benefits: Provides hemispherical diffusion down to 500 Hz by means of triangular scattering cells



Bass Filter / Corner Bass Filter:

Construction: A 24" x 48" (60cm x 120cm) panel consisting of a mineral wool core clad in a plastic lining and wrapped in fabric, 2" (5cm) for standard systems. 4" (10cm) thick for "Plus" system.

Corner Bass Filters have mitered edges to accommodate corner mounting.

Benefits: Provides bass absorption down to 60 Hz without affecting higher frequencies



Ceiling Panel:

Construction: A 24" x 48" x 1" (60cm x 120cm x 3cm) flat panel consisting of a mineral wool core clad in a fiberglass lining and wrapped in fabric

Benefits: Provides absorption down to 300 Hz

Tools and Materials Required

- Screwdriver (Philips or standard depending on the type of fastener)
- 25 Foot (8m) Measuring Tape
- Pencil
- Masking Tape
- Bubble or Laser Level
- Mirror
- Screws or other appropriate fasteners for your wall surface (E-Z Ancor works well for sheetrock)
- Screw Hooks
- Double Stick Foam Tape
- R13 Insulation or Expanding Foam

Panel Placement

Sonata systems are suitable for a wide variety of room sizes. The bigger the larger the number of treatment panels.

The following diagrams show sample room layouts for three ranges of room sizes. For best results, you will need to find the first reflection points between the speakers and the listening position. (See instructions later in this manual.)

Room Size (ft ²)	(m ²)	Kit	Number of Modules
100-200	10-20	150 System	24
200-300	20-30	250 System	28
300-400	30-40	350 System	36
400-500	40-50	450 System	44
500-600	50-60	550 System	51
600-700	60-70	650 System	64

100-200 ft² (10-20 m²) Room Using Sonata 150

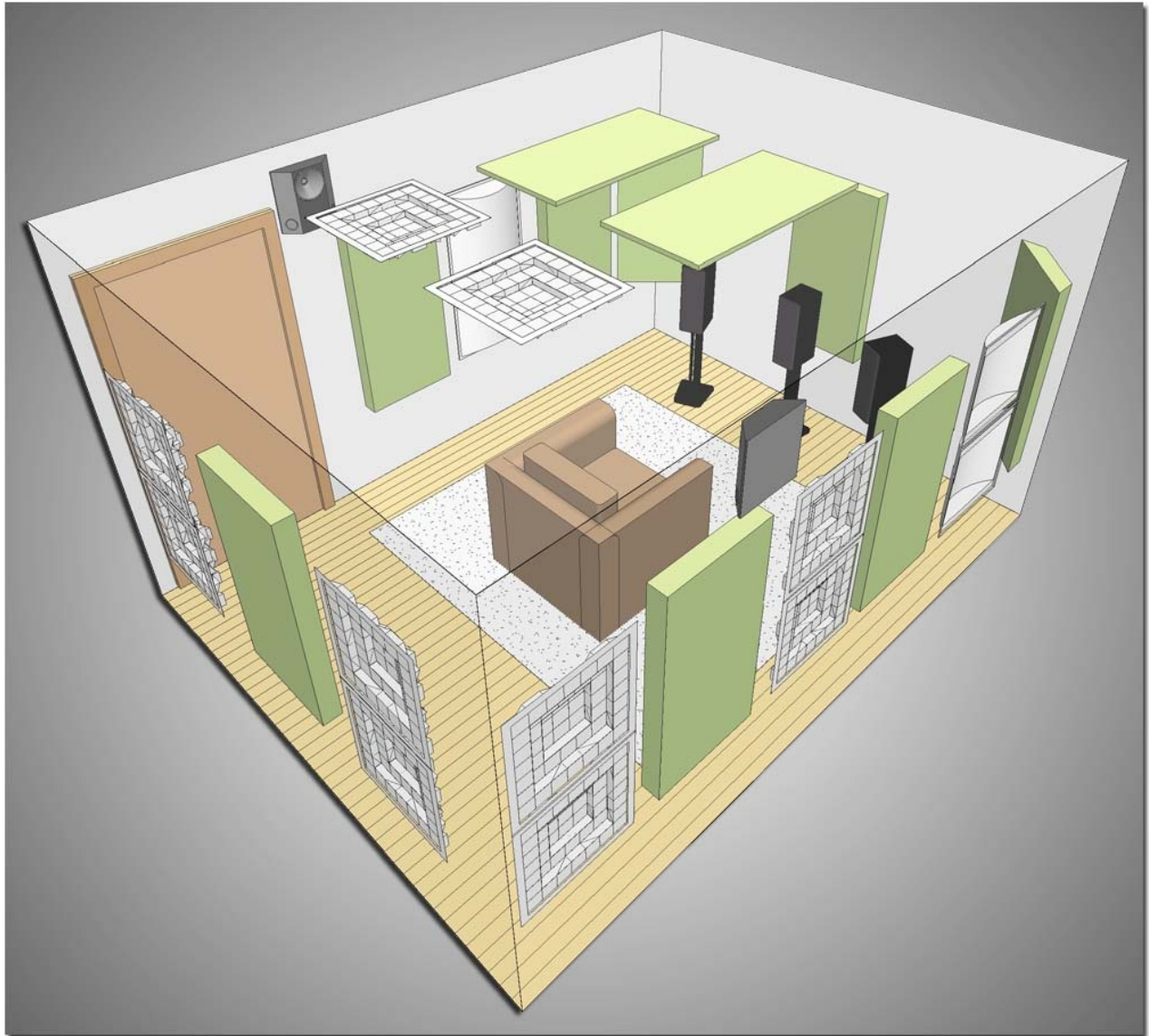

Fig 1

Sonata 150

- 5 Absorbers
- 1 Bass Filter
- 4 DC2 Diffusers
- 10 DR2 Diffusers
- 2 Corner Bass Filters
- 2 Ceiling Panels

200-300 ft² (20-30 m²) Room Using Sonata 250

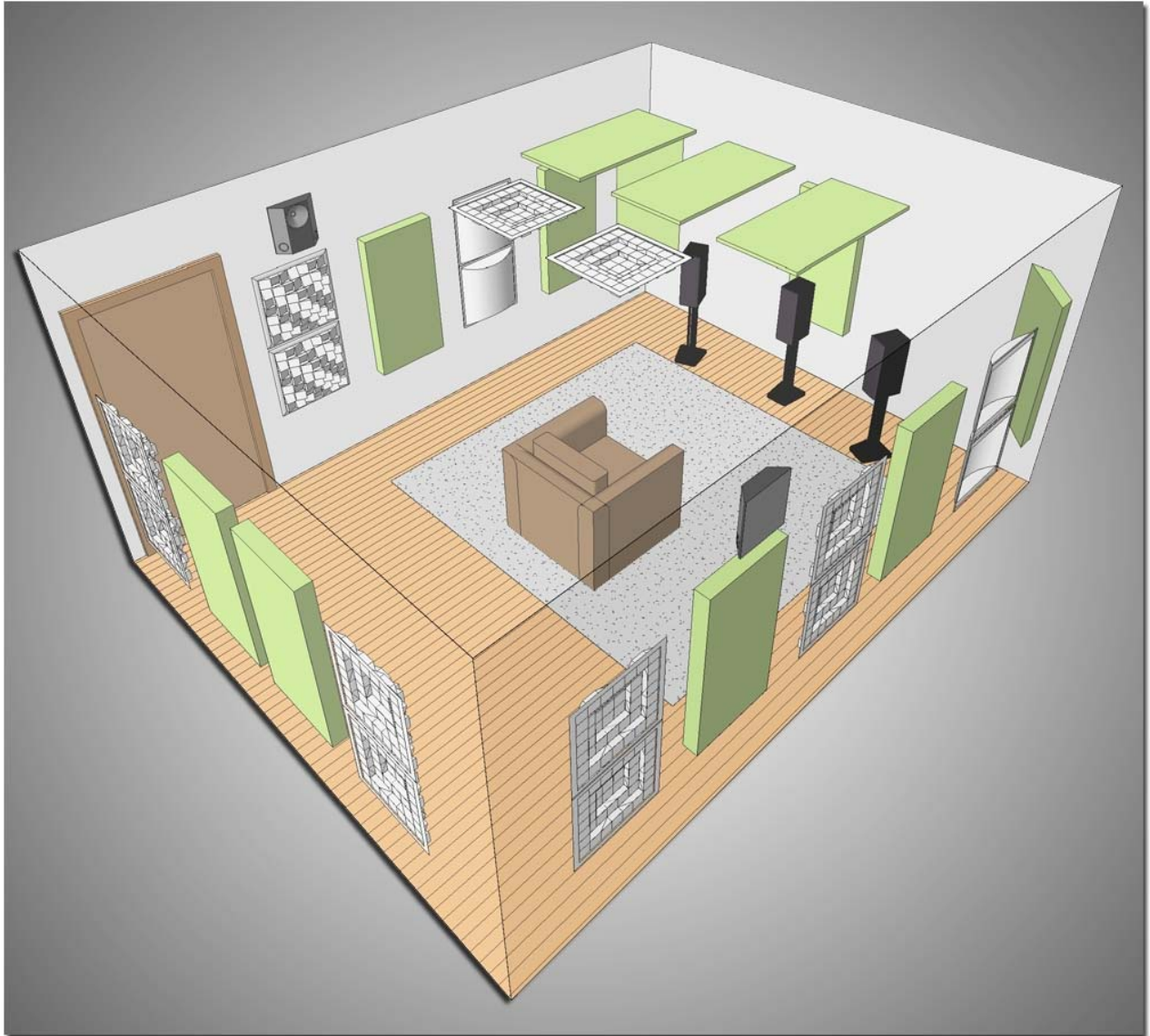

Fig 2

Sonata 250

- 6 Absorbers
- 1 Bass Filter
- 4 DC2 Diffusers
- 12 DR2 Diffusers
- 2 Corner Bass Filters
- 3 Ceiling Panels

300-400 ft² (30-40 m²) Room Using Sonata 350

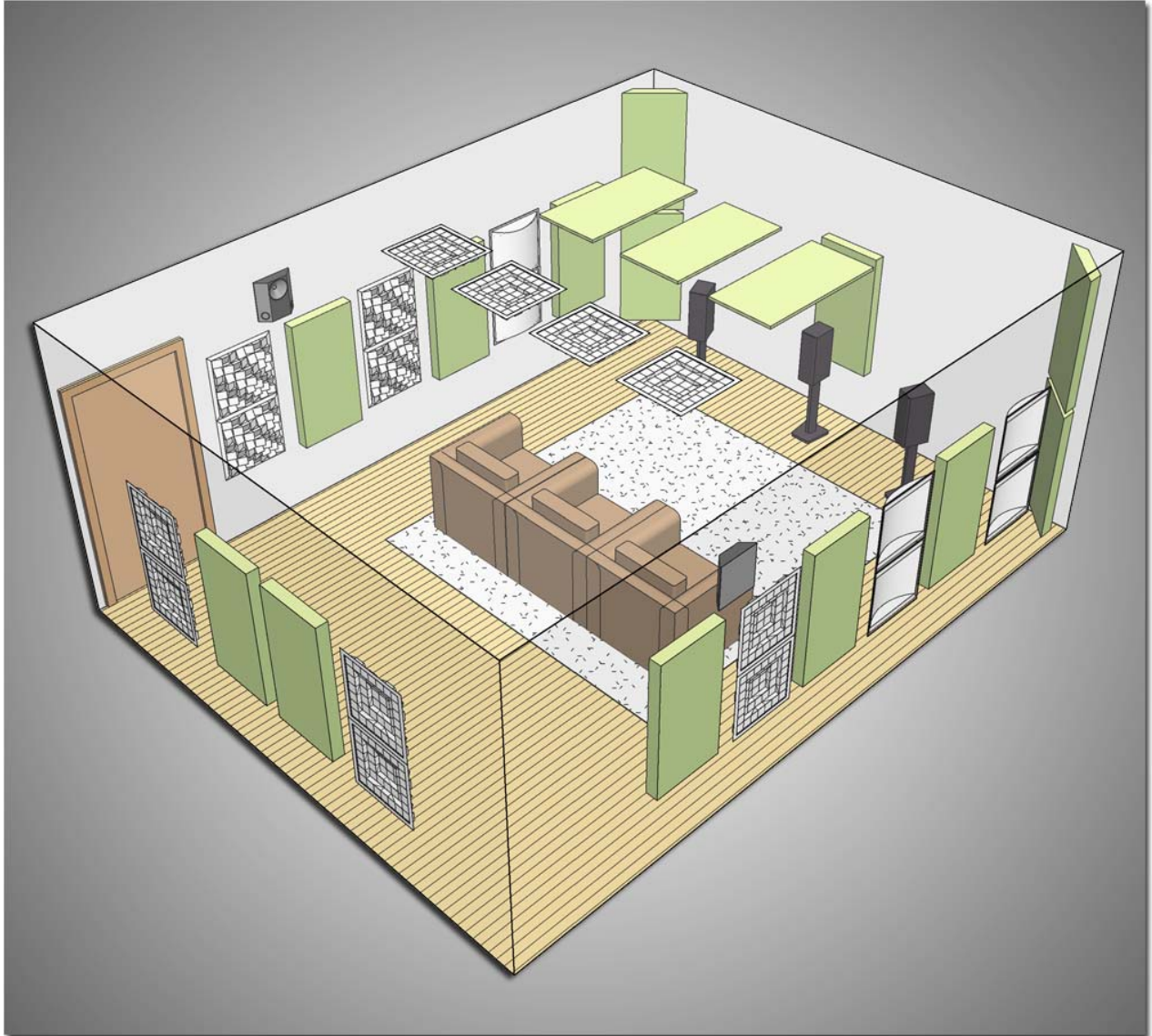

Fig 3

Sonata 350

- 8 Absorbers
- 1 Bass Filter
- 6 DC2 Diffusers
- 14 DR2 Diffusers
- 4 Corner Bass Filters
- 3 Ceiling Panels

400-500 ft² (40-50 m²) Room Using Sonata 450



Fig 4

Sonata 450

- 8 Absorbers
- 1 Bass Filter
- 6 DC2 Diffusers
- 14 DR2 Diffusers
- 4 Corner Bass Filters
- 3 Ceiling Panels

500-600 ft² (50-60 m²) Room Using Sonata 550



Fig 5

Sonata 550

- 11 Absorbers
- 2 Bass Filter
- 10 DC2 Diffusers
- 18 DR2 Diffusers
- 6 Corner Bass Filters
- 4 Ceiling Panels

600-700 ft² (10-20 m²) Room Using Sonata 650

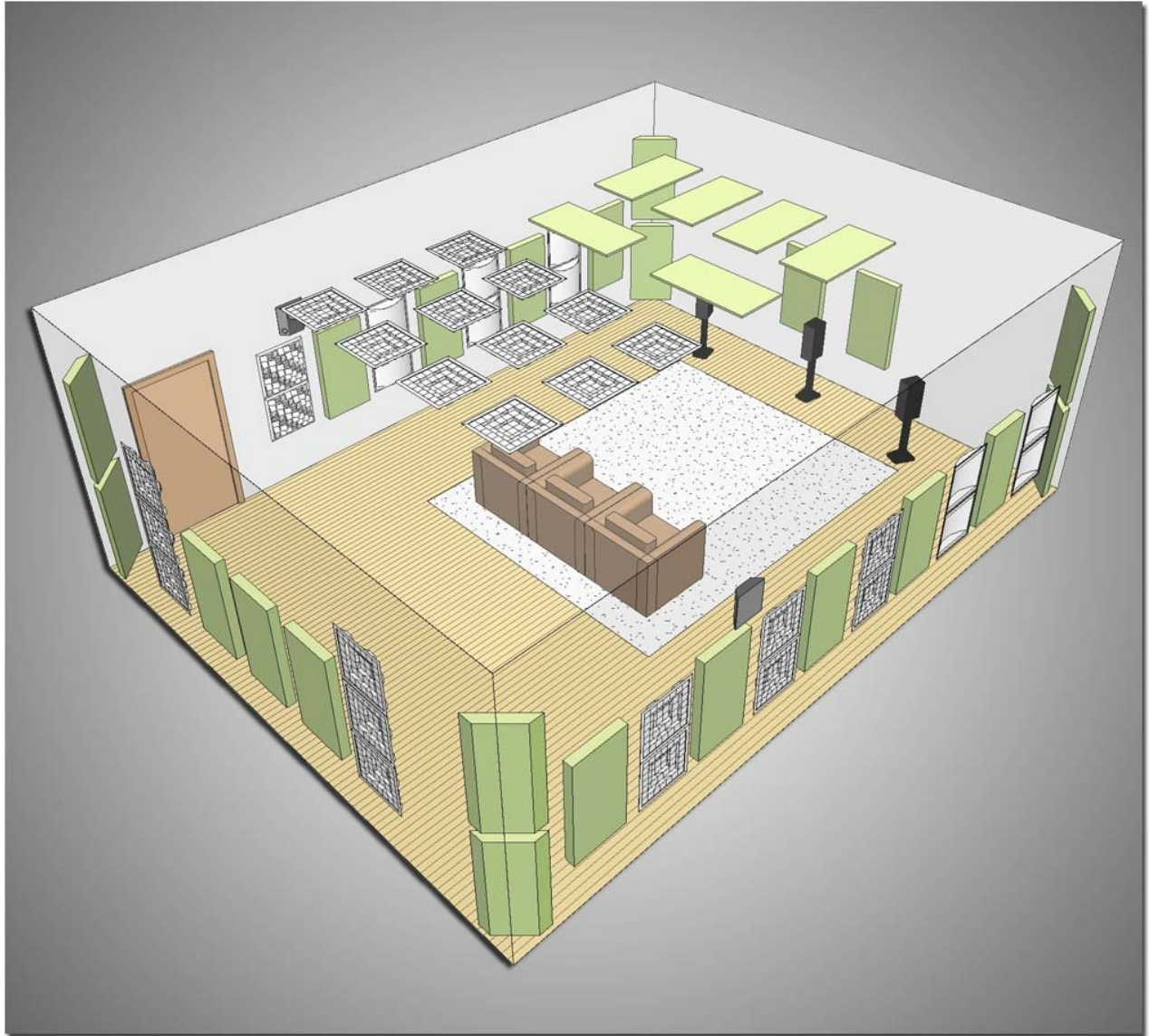

Fig 6

Sonata 650

- 12 Absorbers
- 2 Bass Filter
- 10 DC2 Diffusers
- 26 DR2 Diffusers
- 8 Corner Bass Filters
- 6 Ceiling Panels

Sonata Absorbers

First Reflection Points

The treatment layout shown in fig 1 gives you great control over the acoustic reflections in your room. For further enhancement, ensure that you have placed Absorbers at all the first reflection points on the side and back walls. You can find these by simply using a mirror as shown in fig 7. Sit at the listening position and have someone walk up and down the left wall holding the mirror flat against it. Mark an X at the point where you can see the left speaker in the mirror. Repeat for the right wall and back wall. (You should be able to see both speakers at the first reflection point on the back wall.) Later on, you will be covering these X's with Absorbers.

DC2 and DC4 Diffuser Modules

Place 2D diffuser modules a few inches behind the Absorbers on the side walls as shown in fig 1. Note that 2D diffusers should be oriented to create a horizontally-convex shape (like a vertical column). Feel free to experiment with the DC2 and DC4 placement by listening to the quality of the soundstage and tonal response.

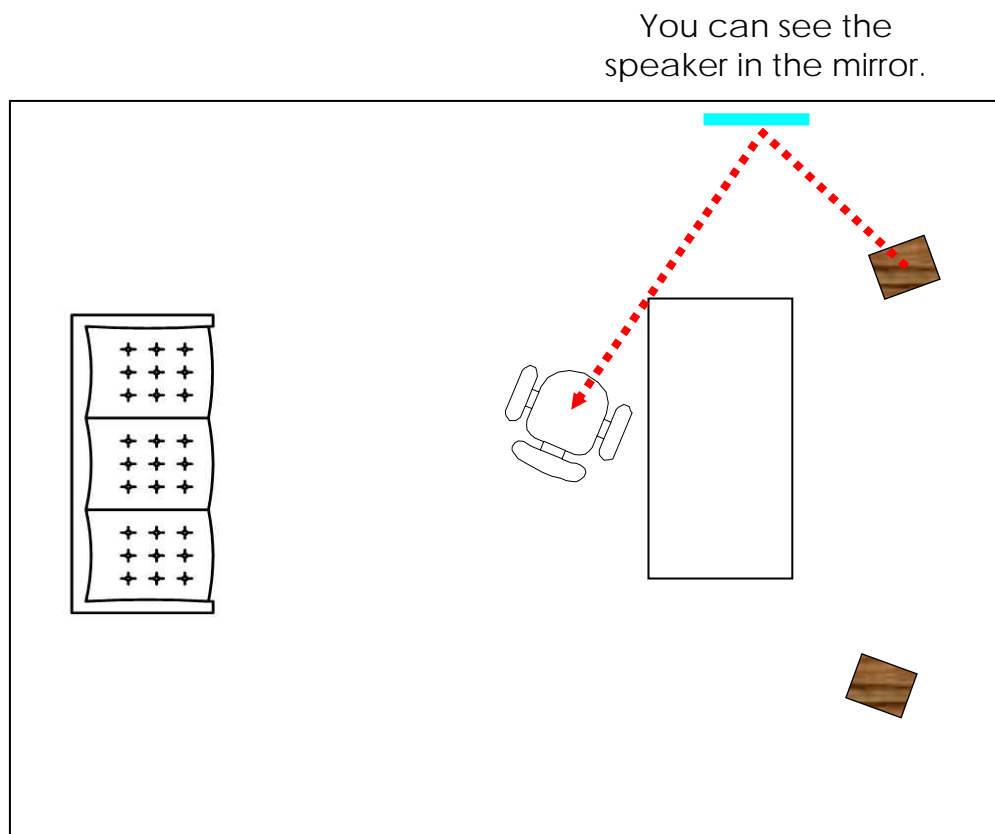

Fig 7 First Reflection Point

DR2 and DR6 Diffuser Modules

Place 3D diffuser modules towards the rear portions of the room on the side walls and the back wall, and on the ceiling, as shown in figures 1 through 3. Feel free to experiment with the DR2 and DR6 placements by listening to the quality of the soundstage and tonal response.

Bass Filter / Corner Bass Filter

The Bass Filter is a mid to low frequency absorption device with an effective bandwidth down to 60 Hz. Bass Filters should be placed at the first reflection points of the front speakers off the front wall. Corner Bass Filters should be placed in the front corners of the room (angled between the front/side wall) near the floor.

Ceiling Panel

The floating Ceiling Panel solves unwanted reflections from the ceiling. Research has shown that ceiling reflections are among the most detrimental to quality sound reproduction.

Hang Ceiling Panels at the first reflection points for the front speakers as shown in fig 8.

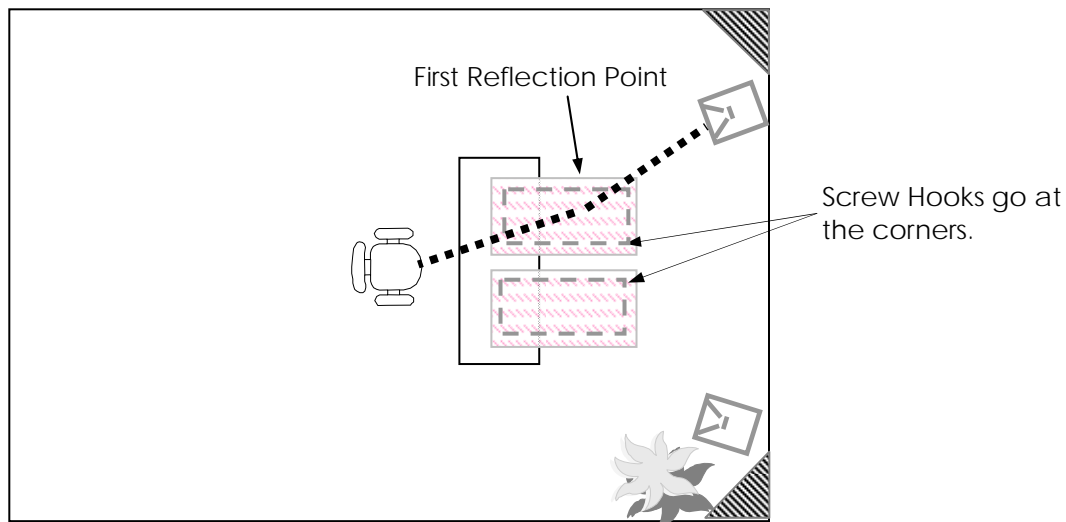

Fig 8 Ceiling First Reflection

Optional Special Products

SpringTrap®

A spring-loaded bass trap, the SpringTrap is our solution to very low frequency room resonance buildup in the range of 40 to 100Hz. This unique patented design, which received the Mix Magazine Certified Hit award, was presented as a research paper at AES in Amsterdam 2003. It consists of a triple-ported resonator system, activated by a large spring-loaded piston diaphragm.



The SpringTrap should be placed in an inconspicuous area in front of the mix position or in a corner on the floor. Experiment with the placement of the SpringTrap. Since it is a triangular device, you should have no trouble finding areas to place it.

Play bass-heavy program material and listen to the bass sound pressure at all the corners of the room. The louder the sound pressure, the stronger the standing wave resonance at that location, and the more effective the SpringTrap will be.

The SpringTrap is not included in the Sonata system. It is available as optional amendment.

Panel Installation

Now that you've located the exact recommended placement for each panel, you can move on to the actual installation. Absorbers and Bass Filters are hung from the walls using the supplied impale clips (fig 9). There are 4 per Absorber or Bass Filter. Please contact MSR immediately if any of the impale clips are missing.

The Ceiling Panels are hung using screw hooks. You will need to supply a total of 4 screw hooks per panel (not included with the Ceiling Panels).

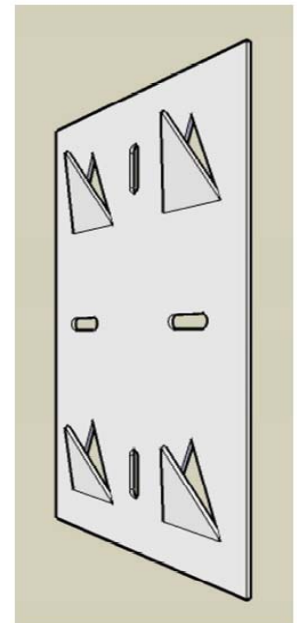
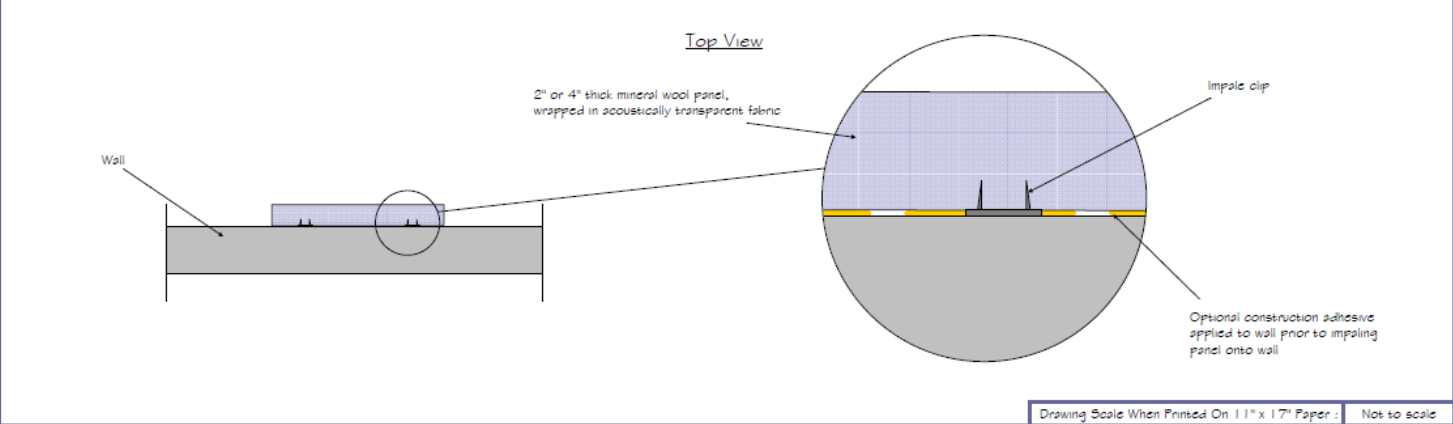
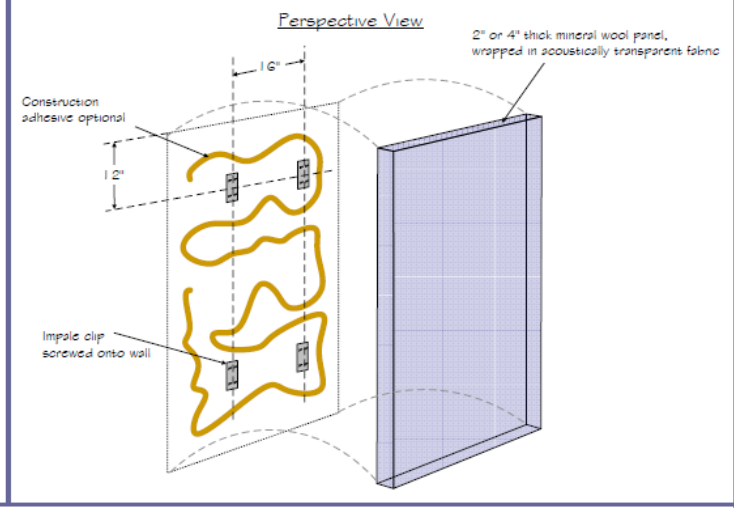
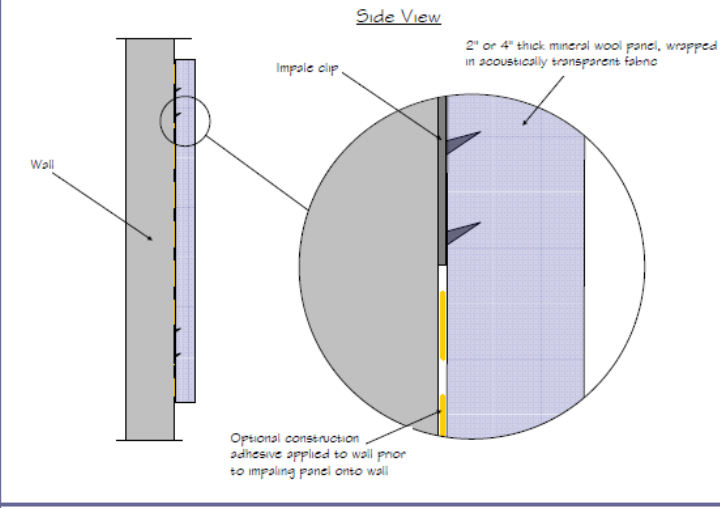

Fig 9 Impale Clip



Drawing Scale When Printed On 11" x 17" Paper : Not to scale

Absorber Panel Mounted With Impale Clips

Absorbers

- Position the Absorbers based on the diagrams and instructions from the preceding pages.
- Mark the first reflection points as described earlier.
- Determine the exact location on the wall for each Absorber. The top edge of the panel should usually be 72 inches (183cm) from the floor, putting the bottom edge at 24 inches (60cm). The middle of the panel should line up with the first reflection point as marked on the wall.
- Attach four impale clips to the wall per Absorber using screws into studs, wallboard inserts and screws, or other appropriate fasteners. The cleats should point up toward the ceiling. The impale clips should go roughly 4 inches inside each corner of the Absorber to avoid interfering with the edge of the fabric wrap. For more permanent installations, you may choose to cover the area behind the Absorber with construction adhesive to reduce the potential for rattles.
- Lift the Absorber up and over the impale clips and drop it on the cleats, applying gentle downward pressure until the panel is caught securely. Note that the Absorber will travel down about ½ inch (1cm) from where it started. You should therefore press it against the impale clips about ½ inch (1cm) above where you want it to end up. Use a bubble or laser level to make sure the Absorber hangs straight.

Diffusers

- Position the diffusers based on the diagrams and instructions from the preceding pages, or as supplied by your acoustical consultant.
- Determine the exact location on the wall for each diffuser. They are usually placed in vertical pairs. The top edge of the top module should be 72 inches (183cm) from the floor, putting the bottom edge of the bottom module at 24 inches (60cm). The middle of the module pair should line up with the first reflection point as marked on the wall.
- Apply a continuous strip of double stick foam tape around the perimeter edge of the back side of each diffuser. This will reduce the potential for rattles. You may wish to leave the adhesive on the wall side covered to facilitate easy removal of the diffuser in the future. Fill the interior cavity of the diffuser with R13 insulation (paper side toward the wall) or expanding foam.
- Note that diffusers may be cut in half to accommodate special mounting applications. When doing so, fill the diffuser with expanding foam prior to cutting it. Use a precision cutting instrument like a Dremmel Tool.
- Screw through the mounting flange at each corner of the diffuser into the wall using 1 inch-long (25mm) drywall screws.

Bass Filters

- Position the Bass Filters based on the diagrams and instructions from the preceding pages, or as supplied by your acoustical consultant.
- Bass Filters attach to the wall in the same manner as Absorbers. Follow the instructions above for Absorbers.

Corner Bass Filters

- Position the Corner Bass Filters based on the diagrams and instructions from the preceding pages, or as supplied by your acoustical consultant.
- In order to hang a Corner Bass Filter in the front corners of the room, you will need to fashion two braces using 2x4 studs, cut to 16 inches (40cm) long (with 4" (10cm) thick panels) with 45 degree angle cuts on each end as shown in fig 10. These braces will span the corner, the impale clips will attach to them, and the Corner Bass Filter will hang from the impale clips. Install one brace centered at a height 6 inches (15cm) up from the panel bottom. Install the second brace centered at 6 inches (15cm) down from the panel top. You will need to do this for every corner. Install the braces with fasteners driven diagonally through the angled cut of the ends of the brace. Preferably drive the fasteners into studs, or you can use wall anchors such as "E-Z Anchor" brand units.
- Attach two impale clips to the top brace and one to the bottom using screws. The spiky cleats should point toward the ceiling as shown in fig 10. The position of the impale clips along the 2x4 brace does not really matter.
- Press the Corner Bass Filter against the impale clips and apply gentle downward pressure until the panel is caught securely. Use a bubble or laser levels to make sure the Corner Trap hangs straight. Note that the Corner Trap will travel down about ½ inch (1cm) from where it started. You should therefore press it against the impale clips about ½ inch (1cm) above where you want it to end up.

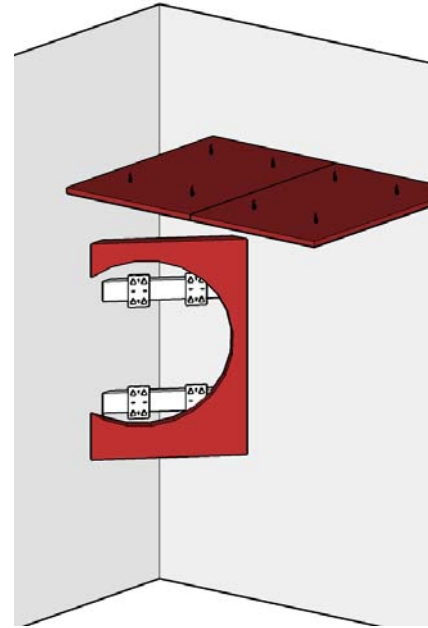
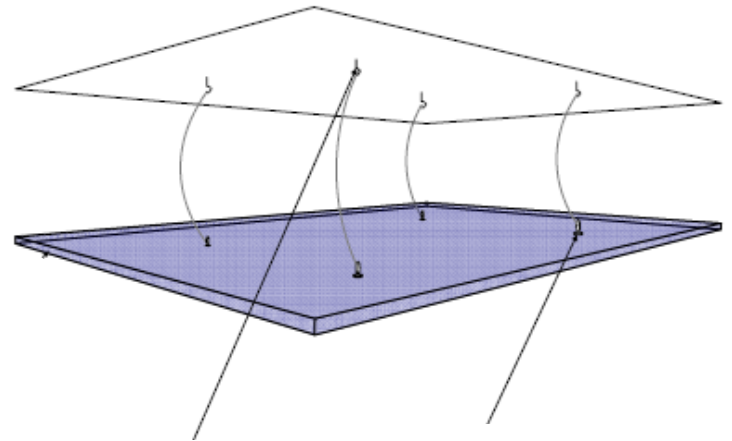

Fig 10 Clip Locations

Ceiling Panels

- Ceiling Panels are hung using Eye Hooks. You will need to supply a total of 4 screw hooks per panel (not included).
- Position the Ceiling Panels based on the diagrams and instructions from the preceding pages, or as supplied by your acoustical consultant.
- Mark the first reflection points as described earlier.
- Determine the exact location on the ceiling for each Ceiling Panel. The center of each panel should line up with one of the first reflection points as marked on the ceiling.
- Screw 4 open screw hooks into the ceiling in a rectangular pattern 36 inches (90cm) by 12 inches (30cm) (6 inches (15cm) inside each edge of the Ceiling Panel). Make sure that you secure the Eye Hooks in joists or use wallboard inserts. After all 4 screw hooks are installed, simply lift the wire loops (pre-installed in the Ceiling Panel) over the hooks. The Ceiling Panel will float a few inches (cm) below the ceiling.



Standard eye hook secures into ceiling assembly. If wood backing is not available, utilize sheetrock anchor system prior to installing eye hooks

Cable loop on back side of cloud panels hang off eye hooks

Care Instructions

The fabric surfaces may be cleaned with mild, water-free solvents or water-based cleaning agents or foam. The plastic surfaces may be cleaned with a lightly dampened cloth.

Spares

If any mounting hardware, panel parts, or extra printed material are needed, please call MSR.

Warranty

All Dimension4 Sonata modules are warranted to be free of manufacturing defects for a period of 12 months from the date of purchase.

Shipping Weight & Dimensions - Sonata Domestic (U.S.A)

System	Components	Units	Weight (lbs)	Box Dimensions (in)		
		Per Box	Total	L	W	H
SōN 150	Absorbers	10	179	29	49	21
	DR2 & DC2	14	40	25	25	18
	Totals	24	219			
SōN 250	Absorbers	12	199	29	49	24
	DR2 & DC2	16	46	25	25	20
	Totals	28	245			
SōN 350	Absorbers	16	239	29	49	32
	DR2	14	42	25	25	18
	DC2	6	16	25	25	7
	Totals	36	297			
SōN 450	Absorbers	20	275	29	49	39
	DR2	16	46	25	25	20
	DC2	8	19	25	25	9
	Totals	44	340			

Shipping Weight & Dimensions – Sonata Plus

System	Components	Units	Weight (lbs)	Box Dimensions (in)		
		Per Box	Total	L	W	H
SōN Plus 150	Absorbers	10	255	29	49	30
	DR6	10	33	25	25	24
	DC4	4	15	25	25	9
	Totals	24	303			
SōN Plus 250	Absorbers	12	259	29	49	43
	DR6	12	39	25	25	26
	DC4	4	15	25	25	9
	Totals	28	313			
SōN Plus 350	Absorbers	16	339	49	53	30
	DR6	14	39	25	25	24
	DC4	6	24	25	25	18
	Totals	36	402			
SōN Plus 450	Absorbers	20	395	49	53	35
	DR6	12	39	25	24	9
	DR6	6	15	25	25	14
	DC4	8	17	25	25	9
	Totals	40	466			

Shipping Weight & Dimensions Sonata –Continued International

System	Components	Units	Weight (kg)	Box Dimensions (cm)		
		Per Box	Total	L	W	H
SōN 150	Absorbers	10	81	74	124	53
	DR2 & DC2	14	19	63	63	45
	Totals	24	100			
SōN 250	Absorbers	12	91	74	124	60
	DR2 & DC2	16	21	63	63	51
	Totals	28	112			
SōN 350	Absorbers	16	109	74	24	82
	DR2	14	19	63	63	45
	DC2	6	7	63	63	18
	Totals	36	135			
SōN 450	Absorbers	20	125	74	124	99
	DR2	16	20	63	63	51
	DC2	8	8	63	63	23
	Totals	44	153			

Shipping Weight & Dimensions – Sonata Plus

System	Components	Units	Weight (kg)	Box Dimensions (cm)		
		Per Box	Total	L	W	H
SōN Plus 150	Absorbers	10	115	74	125	77
	DR6	10	15	63	63	60
	DC4	4	7	63	63	23
	Totals	24	137			
SōN Plus 250	Absorbers	12	118	74	125	109
	DR6	12	18	63	63	63
	DC4	4	7	63	63	26
	Totals	28	143			
SōN Plus 350	Absorbers	16	153	125	135	77
	DR6	14	18	63	63	60
	DC4	6	11	63	63	46
	Totals	36	182			
SōN Plus 450	Absorbers	20	179	125	135	89
	DR6	12	18	63	60	66
	DR6	6	7	63	63	36
	DC4	8	8	63	63	23
	Totals	40	212			



Media Specialty Resources, Inc.
61 Galli Drive, Suite A, Novato, CA 94949, USA
Toll Free: 1-800-497-2087
Phone: 1-415-883 8053
Fax: 1-415-883-8147
Email: info@msr-inc.com
www.msr-inc.com

Dimension4, Dimension4 Sonata, and SpringTrap are trademarks of MSR Inc.
Copyright 2012. Dimension4 Sonata is a quality product from Media Specialty Resources, Inc. Specifications are subject to change without notice.

120711 Sonata Instruction Manual v3